

# BÖLLHOFF

## SITEC®

Fastening elements for vibration and noise decoupling

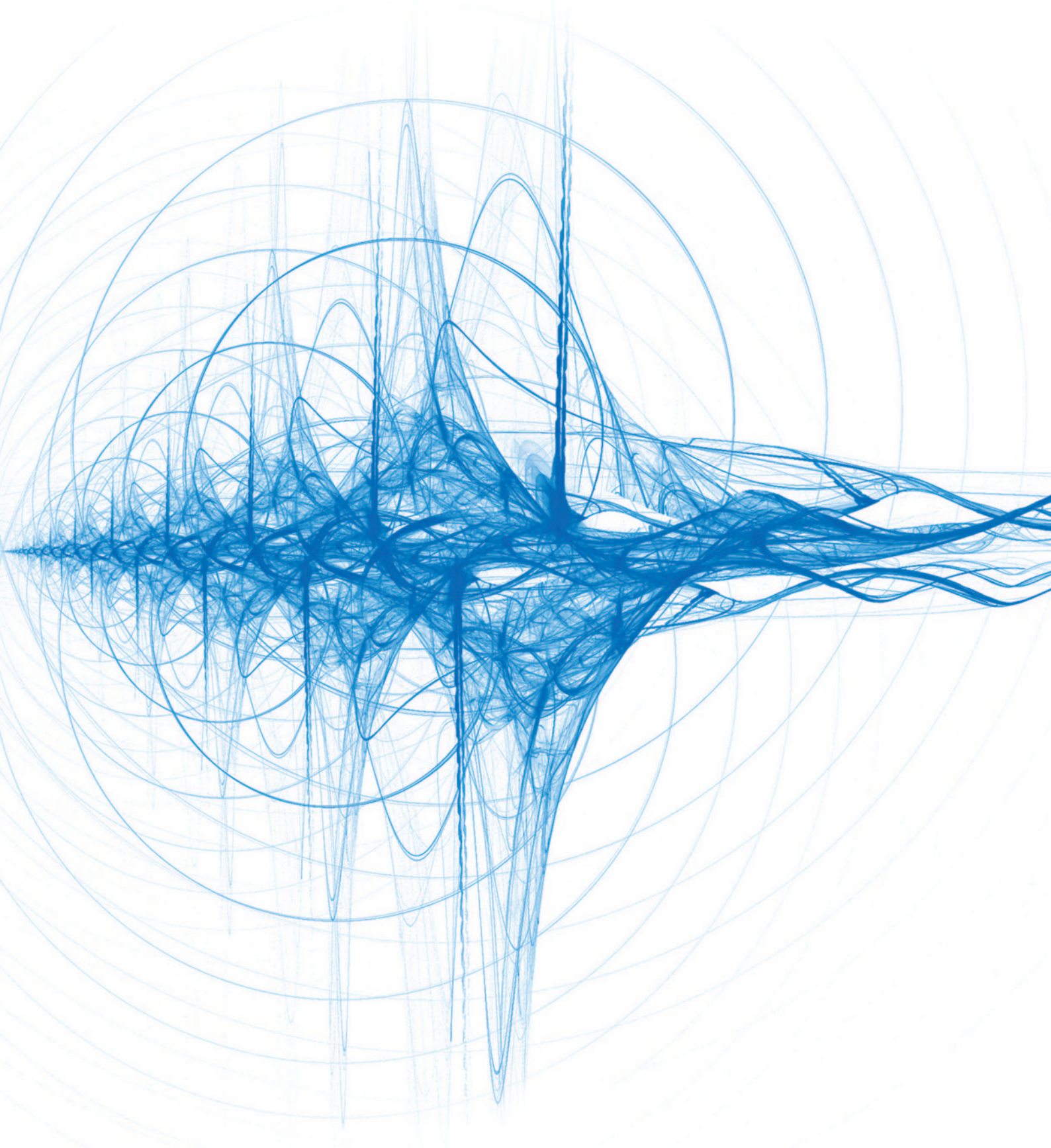



## Silence – a quality factor.

NVH development (NVH = Noise, Vibration, Harshness) is becoming increasingly important. It is present in all industrial sectors from washing machines to vehicles, aircrafts and wind turbines.

NVH stands for:



NOISE, VIBRATION, HARSHNESS

The development is about avoiding vibration and is among the quality characteristics of a product which are most frequently directly observed.

Excessive noise and vibration cause problems. They can affect the performance of a product negatively if it wears out earlier as a result, shows a less efficient performance or – in extreme cases – has a shorter product life due to a mechanical failure.

Let us take a closer look at the vibration technology in cars, for example. In that particular field, the requirements are exceptionally diverse: Engine, body, running gear and other components generate noise and vibration. NVH engineering is a highly complex field. Today's electrified drive trains lead to the formation of new, changed noise characteristics.

It is a real challenge for developers and designers to have the answers to all vibration and acoustics issues.

As an innovative partner in the field of joining technology, we would like to provide support to that respect. One of our aims is to create joining solutions which at the same time reduce vibration and noise.

---

	Page
Vibration technology	5
<b>SITEC®</b> Variants – an overview	6
Materials	8
<b>SITEC®</b> Branches and applications	10
<h2>Damping</h2>	
<b>SITEC®</b> Rivet	12
<b>Standard design</b>	
■ with internal thread	14
■ without internal thread	17
■ Design and geometries	18
■ Choice of screws	19
■ Item codes and specifications	20
<b>Special versions</b>	
■ for high-temperature applications	22
■ for thread-forming screws	24
■ with pre-installed screw	25
<b>SITEC®</b> Pin	26
<b>SITEC®</b> Clip	30
<h2>Isolation</h2>	
<b>SITEC®</b> Spring	34
The Böllhoff competencies	38

The new product group of **SITEC® vibration and noise decoupling fastening elements** is our answer to today's trend toward the NVH development. We only address vibrations produced by actuators such as pumps, compressors and engines. There are different approaches to reduce noise and vibration:

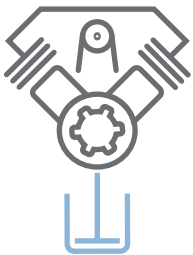

### 1) Damping

One method to reduce vibration and the resulting noise emission is damping. During material-based damping, kinetic vibration energy/energy is converted into thermal energy. The principle of damping describes the reduction of an output quantity over time. Such conversion can be realised with the SITEC® fastening elements when using technical elastomers. Detailed information is provided on page 8 in the "Materials" section.



### 2) Isolation

Another method to reduce noise emission is the vibration isolation. In contrast to damping, there is no conversion of energy to reduce the amplitude, but a detuning of vibration. With this principle, an excitation is directly absorbed by an elastic fastener and only transferred with a considerably reduced amplitude through a tuned spring rate. This type of reduction is primarily employed for strongly vibration-emitting applications.



After this short excursion into vibration technology, we would like to introduce our new SITEC® product group to you. The following illustration provides a first impression of the product variants. Starting point are the possibilities of connection to the mounting part:

## VIBRATION AND NOISE DECOUPLING

Plug-in connection



**SITEC® Pin**



**SITEC® Rivet**

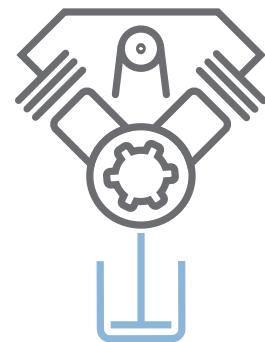

**Damping**

Screw joint



**SITEC® Clip**



**SITEC® Spring**

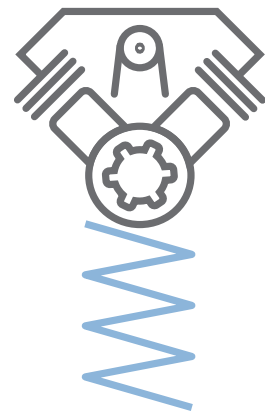

**Isolation**

Apart from the sophisticated geometry of the SITEC® fastening elements, the technical elastomers are the basis for intelligent joining solutions in vibration technology. There are three different manufacturing materials. The main characteristic on which to base the choice of material is the continuous operating temperature. In a further step, the Shore hardness of the individual materials can be chosen.

Depending on the requirements for your product, we decide on the appropriate material. Since we closely cooperate with leading raw material manufacturers, new perspectives are constantly emerging.

**The distinctive features of the materials are listed in the following tables:**

Properties
Hardness (Shore)
Temperature resistance
Test temperature levels for assembly and disassembly forces
Thermal behaviour
Abrasion resistance
Compression set (at room temperature)
Oil resistance
Acid resistance
Alkali resistance
Ozone and weathering resistance





**Cross-linked elastomers/rubber**

**EPDM Peroxid**

30A-90A

-40 °C to +140 °C

-20, RT, +80, +100, +140

+

+/0

++

-

++

++

++

**VMQ**

30A-80A

-40 °C to +180 °C

-20, RT, +80, +140, +180

++

-

++

0

-

++

++

**Thermoplastic elastomer**

**EPDM-X+PP**

35A-50D

-40 °C to +100 °C

-20, RT, +80, +100, +120

0

-

+

-

++

++

++

- Good temperature resistance between approx. -40 °C and +140 °C
- Very good compression set
- Good resistance to chemicals
- Good resistance to mineral oils and greases

- Very good temperature resistance between approx. -40 °C and +180 °C
- Excellent ageing resistance
- Low effect of temperature variations on the mechanical properties

- Good mechanical properties between approx. -40 °C and +100 °C
- Good compression set
- Good resistance to chemicals
- Good resistance to mineral oils and greases



++ very good, + good, 0 average, - bad

## Customised solutions

Within the framework of a project, new developments according to your application-specific requirements can be realised at any time.

We precisely incorporate your concepts and ideas to be able to offer you the best solution for your application.

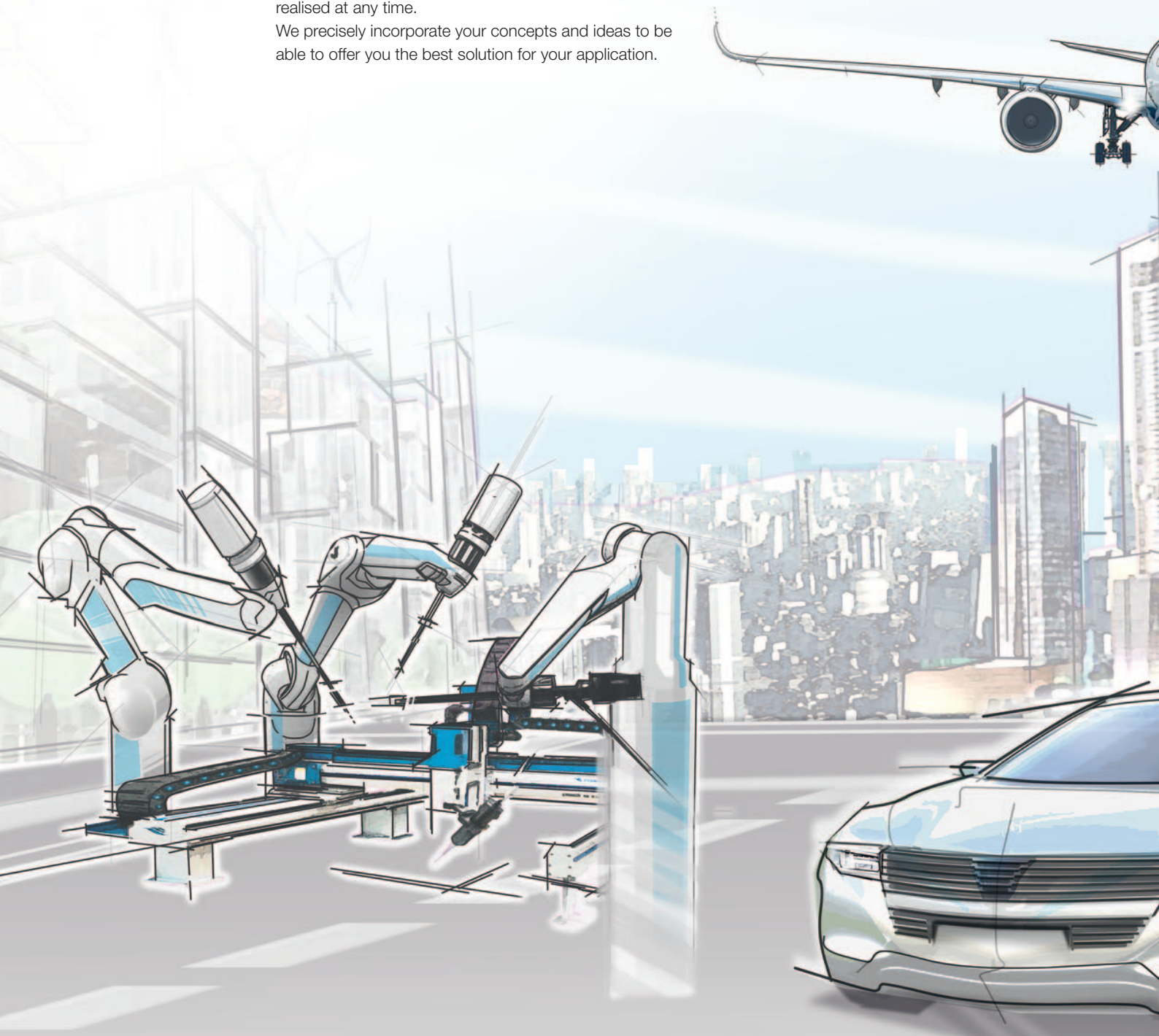

### **Automotive**

- Engine and units
- Electronics
- Cooling systems
- Air systems
- Drive technology

### **Automotive applications**

- Auxiliary heating system
- Brake unit
- Circulating water pump
- Coolant pump
- ESC aggregate
- Inverter
- Main radiator
- Soundbox
- Switching valves
- Valve block
- ...

**Industry**

- Public health engineering
- Household appliances
- Electrical engineering
- Energy technology
- Drive technology

**Industry applications**

- Pumps
- Fans
- Heat exchangers
- ...



	Page
Vibration technology	5
<b>SITEC®</b> Variants – an overview	6
Materials	8
<b>SITEC®</b> Branches and applications	10
<b>Damping</b>	
<b>SITEC®</b> Rivet	12
<b>Standard design</b>	
■ with internal thread	14
■ without internal thread	17
■ Design and geometries	18
■ Choice of screws	19
■ Item codes and specifications	20
<b>Special versions</b>	
■ for high-temperature applications	22
■ for thread-forming screws	24
■ with pre-installed screw	25
<b>SITEC®</b> Pin	26
<b>SITEC®</b> Clip	30
<b>Isolation</b>	
<b>SITEC®</b> Spring	34
The Böllhoff competencies	38

## SITEC® Rivet – standard design with internal thread



As a fastening technology expert, Böllhoff has recognised the special role of plastics quite early. Already for decades, we have been producing precision plastic parts. It goes without saying that synergies with other joining technologies have resulted from the growing expert knowledge in the plastics technology so that new innovative products have been developed — such as the RIVKLE® Elastic.

This decoupling blind rivet nut allows to fasten a high-strength thread body to a thin-walled component with an additional vibration and noise decoupling effect.

In the late 1980s, the first RIVKLE® Elastic was produced laying the foundation for the SITEC® product family. Today, we incorporate this joining variant, which has already been tried and tested, under the new brand name of SITEC® Rivet into the SITEC® product family.

### Application example

Among other industries, the SITEC® Rivet is employed in the automotive sector, for example to fasten engine spoilers, filters or compressors. The illustration below shows the SITEC® Rivet as a possible joining solution for the EV inverter in an electric car including guideline values for the technical design.

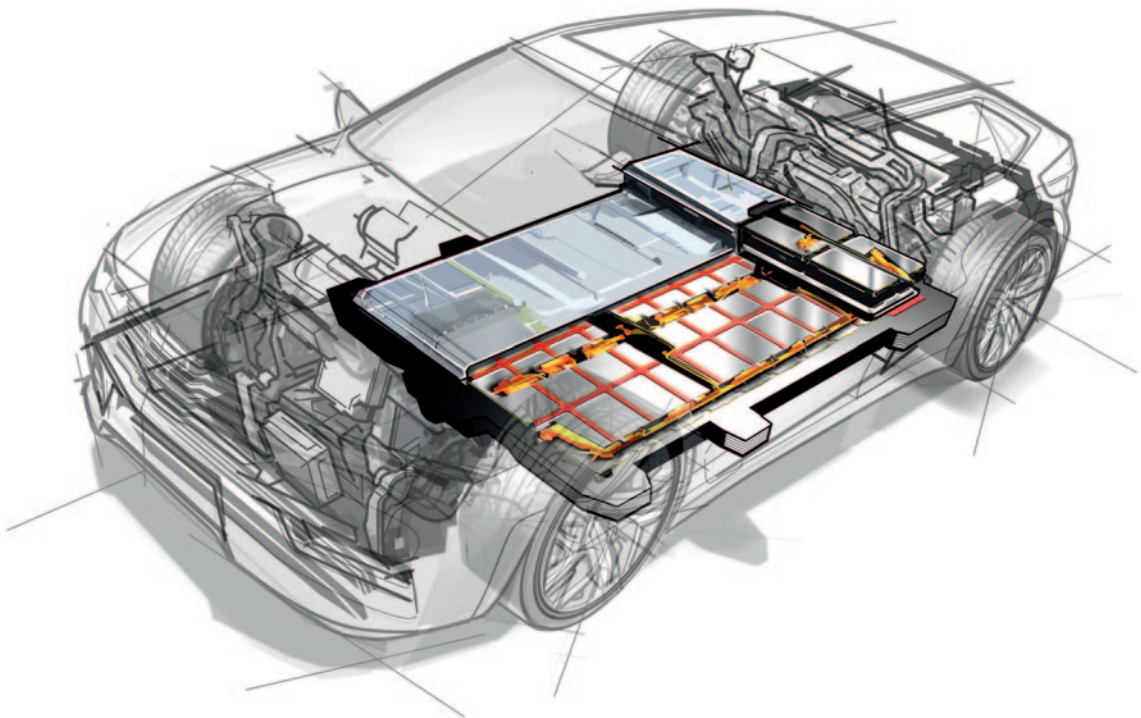

SITEC® Rivet  
The decoupling blind rivet nut  
– one-piece system

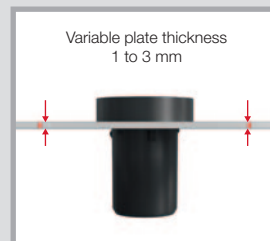

1) Pressing the SITEC® Rivet into the bore hole on the receiving part  
2) Clamping ribs for loss protection



Alignment of the mounting part on the pre-installed SITEC® Rivet

## Function

The SITEC® Rivet consists of a metal sleeve which is usually a brass sleeve with a metric thread which is covered with elastomer or thermoplastic elastomer.

Apart from the fastening function, the main benefit of the SITEC® Rivet is the vibration and noise decoupling characteristic. This is achieved by the elastomer covering.

Since the metal sleeve (standard design: brass) is only connected to the covering in the bottom part, a bulge forms on the rear of the component to be fastened when a screw is screwed in. The result is a reliable and reversible blind rivet joint with damping function.

### Technical data – an overview (guideline values)

- Force for the installation in the application < 20 N
- Screw size M 6
- Screw tightening torque: 4.5 Nm
- Grip length: 0.5–3.0 mm
- Weight to be fastened: approx. 3.5 kg
- Material: EPDM-X+PP



### Your advantages – an overview

- Vibration and noise decoupling
- Thermal and electrical insulation
- Stable thread on thin-walled components
- Adjustable parameters for a flexibility in design (material, connection solution)
- One-sided installation without loss of performance – blind installation
- Fast and easy installation – screwing and setting are the same



Introduction of a screw through the bore hole on the mounting part and screwing together with the SITEC® Rivet

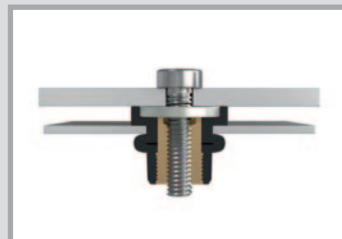

During screwing, a rivet bulge forms on the rear below the receiving part.



Screwing process complete; screw joint with damping effect



<https://www.boellhoff.com/video/sitec-rivet>

## SITEC® Rivet – standard design with internal thread



As a standard, the **SITEC® Rivet** is available in two basic designs:

- SITEC® Rivet with washer
- SITEC® Rivet without washer

The variant with washer is used as a damping joint for plastic, aluminium, composite or steel components with slotted holes.

The advantage is that the force distribution is improved with the built-in washer and the component to be joined is not damaged.

To join steel components (through hole as per DIN ISO 273), the SITEC® Rivet without washer can be used. There is then the additional advantage of a smaller head height which therefore accordingly reduces the required installation space.

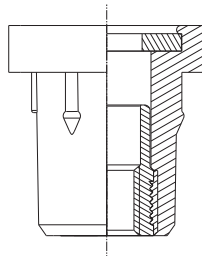

SITEC® Rivet with washer

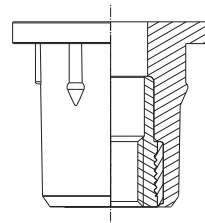

SITEC® Rivet without washer

With the internal thread which is already built into the metal insert no additional thread is required in the receiving part.

The standard designs of the SITEC® Rivet are available in four sizes M 4, M 5, M 6 and M 8. The parameters of shank length and diameter, metal sleeve, type, diameter and length of thread, colour and material as well as the surface of the metal sleeve can be varied.



**SITEC® Rivet** – standard design without internal thread



The SITEC® Rivet without internal thread offers further joining options. Since a fastening thread (such as a weld nut) is required on the other component, larger wall thicknesses (or spacings) can be spanned and the components can be joined with a damping effect.

As opposed to the variant with built-in internal thread, the rivet bulge is shaped between both components in the screw-in process. The SITEC® Rivet is simply inserted into the existing bore on the component to be fastened and screwed into the weld nut (or similar) on the mounting part using a metric screw. The wall thickness of the mounting part and a possible spacing determine the length of the screw to use.

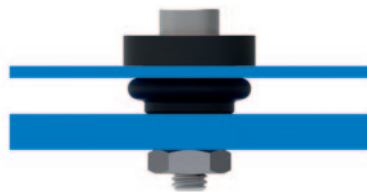

SITEC® Rivet without thread, installed

Moreover, the clearance in the brass sleeve allows a radial tolerance compensation.

**Technical data**

**SITEC® Rivet without internal thread**

Covering: Material: EPDM-X+PP 59 Shore A, black  
Sleeve: brass; washer: brass, nickel-plated

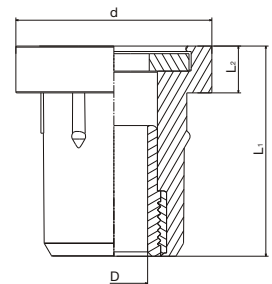

Item number	Version	D	d	L <sub>1</sub>	L <sub>2</sub>	Mounting hole D <sub>1</sub>	Setting height	Grip length
2431 362 0300	with washer	6.2	18	19.3	4.3	13.0 + 0.2	10.0	0.5–3.0

The above values have been compiled to the best of our knowledge and are considered to be the typical guideline values. They cannot be used as templates for specifications. Despite these guideline values, the items must still be checked for your purposes and processes.

## Head

Part of the SITEC® Rivet which rests on the workpiece surface.

## Shank

Part of the SITEC® Rivet underneath the head.

## Clamping ribs

Until the joint is further fastened, the clamping ribs function as a loss protection.

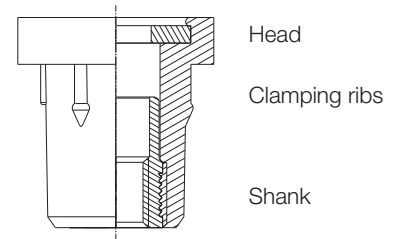

## Grip length

This length is the material thickness of one or several workpieces into which the SITEC® Rivet is installed. The material thickness must range between the minimum and maximum value for which the SITEC® Rivet is designed.



## Dimension of the mounting hole

The dimension is specified as diameter  $D_1$  for the cylindrical mounting hole.

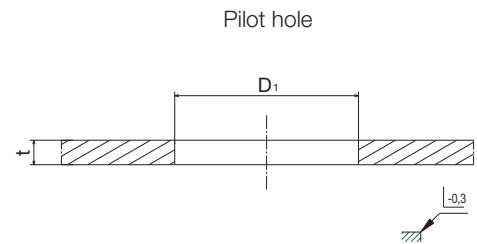

## Bore hole in the mounting part

The recommended diameter for the bore hole in the mounting part must be defined according to DIN ISO 273 (medium).

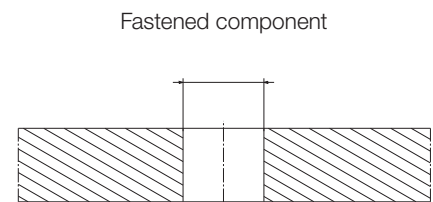

## Measure of the installation situation

The height after setting is specified as "L".

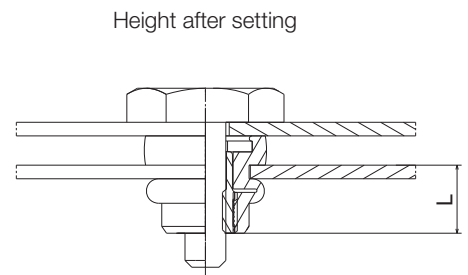

**SITEC®** Choice of screws

The SITEC® Rivet nut thread is produced with the common dimensional tolerance (6H, as per ISO 68-1). It is designed to be used with screws of 6 g tolerance. American/British threads can also be produced.

**Mechanical properties – Tightening torque  $M_A$**

Sizes	Tightening torque $M_A$ max. (Nm)
M 4	2.0
M 5	2.0
M 6	4.5
M 8	7.0

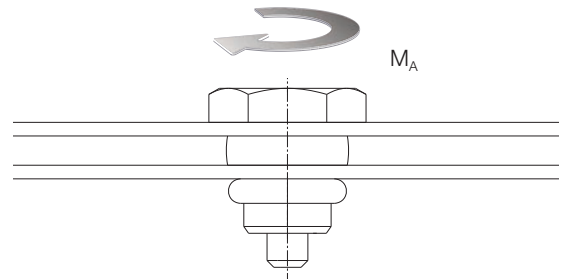

Test method to determine the torque on the SITEC® Rivet with washer

**Mechanical properties – Installation force  $F_M$**

Sizes	Installation force $F_M$ [N]
M 4	20
M 5	19
M 6	18
M 8	61

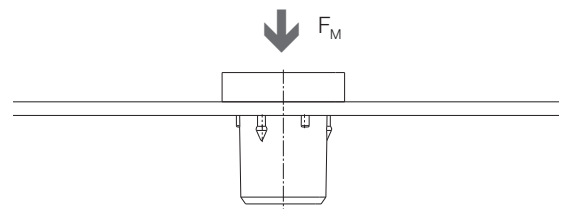

Test method to determine the installation force prior to setting

Installation at room temperature

**Maximum width of the upset metal ( $w$ )**

Sizes	Max. width of upset metal $w$ (mm)
M 4 / M 5	15.0
M 6	15.5
M 8	20.5

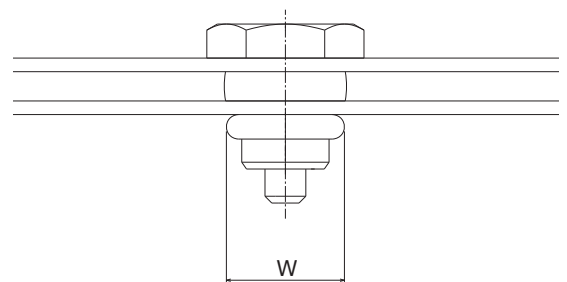

Measurement of the maximum width of upset metal

**SITEC® Rivet with washer**

Covering: EPDM-X+PP, 69 Shore A  
 Colour: black  
 Thread insert: brass  
 Washer: brass, nickel-plated

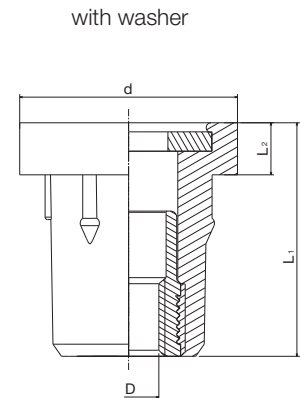

Item number	Version	D	d	L <sub>1</sub>	L <sub>2</sub>	Mounting hole D <sub>1</sub>	Setting height	Grip length
2431 004 0300	with washer	M 4	15	17.7	3.7	10.3 + 0.2	9	0.5–3.0
2431 005 0300	with washer	M 5	15	17.7	3.7	10.3 + 0.2	9	0.5–3.0
2431 006 0300	with washer	M 6	18	19.3	4.3	13.0 + 0.2	10	0.5–3.0
2431 008 0300	with washer	M 8	22	21.6	5.6	16.0 + 0.2	11	0.5–3.0

**SITEC® Rivet without washer**

Covering: EPDM-X+PP, 69 Shore A  
 Colour: black  
 Thread insert: brass

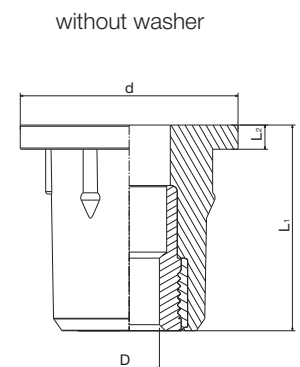

Item number	Version	D	d	L <sub>1</sub>	L <sub>2</sub>	Mounting hole D <sub>1</sub>	Setting height	Grip length
2430 004 0300	without washer	M 4	15	15.5	1.5	10.3 + 0.2	9	0.5–3.0
2430 005 0300	without washer	M 5	15	15.5	1.5	10.3 + 0.2	9	0.5–3.0
2430 006 0300	without washer	M 6	18	17.0	2.0	13.0 + 0.2	10	0.5–3.0
2430 008 0300	without washer	M 8	22	19.0	3.0	16.0 + 0.2	11	0.5–3.0

The above values have been compiled to the best of our knowledge and are considered to be the typical guideline values. They cannot be used as templates for specifications.

Despite these guideline values, the items must still be checked for your purposes and processes.

**SITEC® Rivet with internal thread**

Covering: VMQ, 70 Shore A  
 Colour: black  
 Sleeve: brass

without washer

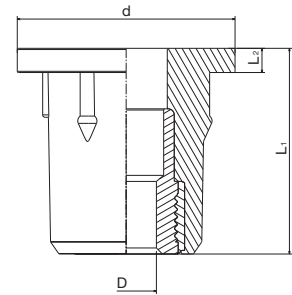

Item number	Version	D	d	L <sub>1</sub>	L <sub>2</sub>	Mounting hole D <sub>1</sub>	Setting height	Grip length
2430 206 0300	without washer	M 6	18	17.0	2.0	13.0 + 0.2	10.0	0.5-3.0

The above values have been compiled to the best of our knowledge and are considered to be the typical guideline values. They cannot be used as templates for specifications.

Despite these guideline values, the items must still be checked for your purposes and processes.

## SITEC® Rivet HT – Special versions for high-temperature applications

---

This special decoupling blind rivet nut can be used to meet special requirements for continuous operating temperature, tightening/loosening torque as well as tensile/shear load.

That is achieved with a combination of metal bush, covering of elastomer or thermoplastic elastomer plus an additional sleeve.

The sleeve creates a positive connection between the decoupling covering and the metal bush. The optimised part geometry of the SITEC® Rivet HT allows to reliably fasten components even under higher loads and temperatures while at the same time decoupling them.

As required, the sleeve can be delivered in metal or plastic.



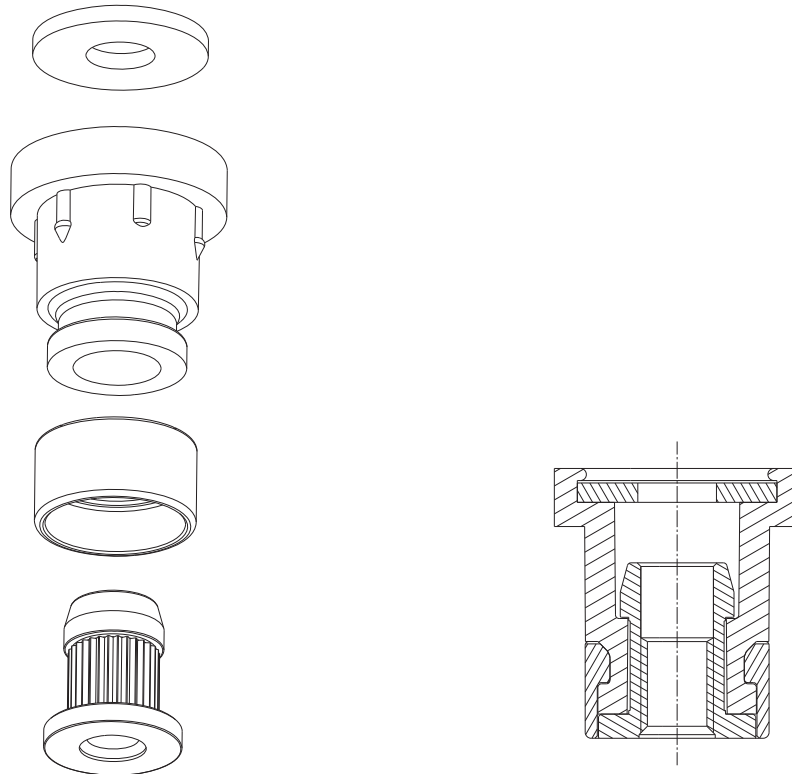

SITEC® Rivet HT for high temperatures  
– exploded view

SITEC® Rivet HT – sectional view

### Installation



Pressing into the receiving part

Placing the component to be fastened and screwing

SITEC® Rivet HT: screwing complete = setting

#### Your advantages – an overview

- One-sided accessibility for installation
- For joints with higher requirements for continuous operating temperature, tightening/loosening torque and tensile/shear load
- Fastening of the application with decoupling effect
- Detachable riveted joint
- Optimised part geometry

Available on request. Please do not hesitate to contact us.

## SITEC® Rivet – Special version for thread-forming screws



This variant from the assortment of SITEC® Rivets offers another fastening option. It is completely made of plastic and can be used for a thread-forming screw.

Installation is easy. The rivet is inserted from one side into the hexagon socket of the support part. The clamping ribs serve as a loss protection until the final fastening.

The internal plastic sleeve is only connected to the thermoplastic elastomer covering in the lower part. So a bulge forms on the rear of the component to be fastened when a common thread-forming screw 4 x 14 is screwed in.

Due to the hexagon geometry, the fastener does not rotate during screwing-in. The resulting joint decouples vibration and noise.

### Installation



Pressing into the receiving part

Placing the component to be fastened and fastening with a thread-forming screw

SITEC® Rivet: screwing complete = setting

### Your advantages – an overview

- One-sided installation without loss of performance
- Fastening with thread-forming screws
- Thread body for thin-walled components with vibration and noise decoupling
- Reversible riveted joint
- Full-plastic solution

Available on request. Please do not hesitate to contact us.



**SITEC® Rivet** – Special version with pre-installed screw



The SITEC® Rivet with pre-installed screw can be used for the intelligent fastening of applications. At the same time, installation times are shortened.

The fastener which is designed as an assembly, is simply inserted into the mounting hole of the component and screwed together with another component.

**Function**

While the screw is screwed in, a rivet bulge forms between the components to be fastened. To fasten the screw, a thread is required in the second component. Due to a smart choice of material, this fastener also has a damping effect. Fast and easy.

The damping fastener can also compensate radial tolerances and is suited for different grip lengths.

**Installation**



SITEC® Rivet with pre-installed screw, inserted



SITEC® Rivet with pre-installed screw, fastened



<https://www.boellhoff.com/video/sitec-rivet-without-internal-thread>

**Your advantages – an overview**

- Shorter installation times: Easy, one-sided installation
- Tightening torque according to property class 8.8
- Radial tolerance compensation of  $\pm 1$  mm
- Defined component spacing
- Different grip lengths

Available on request. Please do not hesitate to contact us.



	Page
Vibration technology	5
<b>SITEC®</b> Variants – an overview	6
Materials	8
<b>SITEC®</b> Branches and applications	10
<h2>Damping</h2>	
<b>SITEC®</b> Rivet	12
<b>Standard design</b>	
■ with internal thread	14
■ without internal thread	17
■ Design and geometries	18
■ Choice of screws	19
■ Item codes and specifications	20
<b>Special versions</b>	
■ for high-temperature applications	22
■ for thread-forming screws	24
■ with pre-installed screw	25
<b>SITEC®</b> Pin	26
<b>SITEC®</b> Clip	30
<h2>Isolation</h2>	
<b>SITEC®</b> Spring	34
The Böllhoff competencies	38

# SITEC® Pin



The SITEC® Pin is a detachable plug-in connection. It is used whenever damping joining solutions are required.

The SITEC® Pin consists of a plastic stud and a soft damping element. This can be produced from thermoplastic elastomer, rubber or silicone. With two undercut geometries, this fastener smoothly fits into bore holes in different plate thicknesses without the use of a tool.

## Application example

The SITEC® Pin is perfectly suited to fasten lightweight applications. With its design, it can be used to fasten and decouple switching valves, for example, with an additional damping effect.

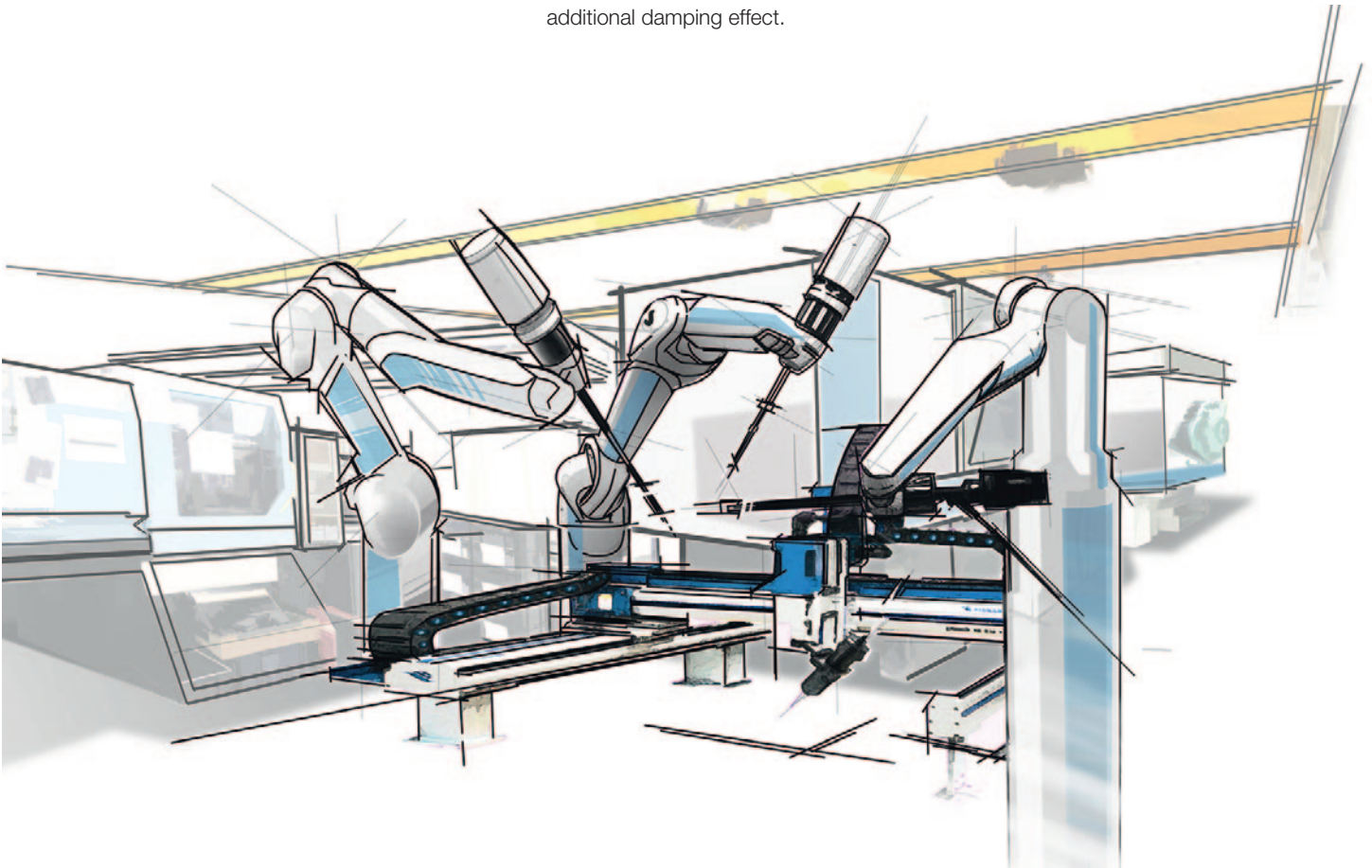

SITEC® Pin  
The decoupling plug-in  
connection  
– two-piece system



Simple pressing into the  
bore hole in the mounting  
part



Due to undercut: pre-installation in the mounting part with loss protection

## Function

The SITEC® Pin is used to join two plate geometries fast and easily. The fastener – supplied as an assembly – can be pre-assembled in the application so that it is safe to transport. Later it is inserted at the mounting geometry and locked with the bolt.

The damping effect of the soft material and the adapted geometry easily physically convert vibration in your application into heat. That reduces and flattens the peaks of the amplitude.

The functional principle of the SITEC® Pin has been designed for all applications of this type. Please find below the technical data for this application.

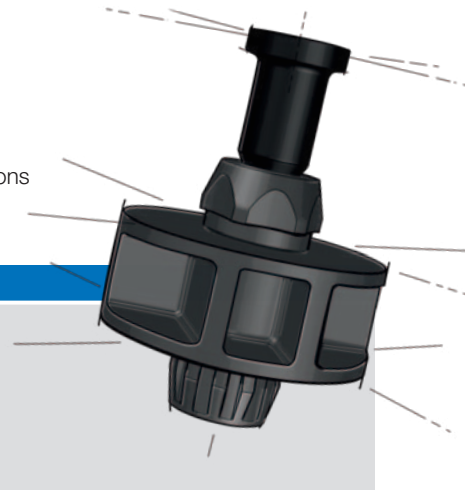

### Technical data (guideline values)

- Installation force – fastener in the application: 20 N
- Installation force – Pin in final installation: 30 N
- Weight to be fastened: approx. 0.5 kg
- Continuous operating temperature: –40 °C to +180 °C
- Material: VMQ

### Your advantages – an overview

- Vibration and noise decoupling
- Pre- and final installation
- Fast, easy and with loss protection
- Without tool
- Range of use – component thicknesses between 1 and 3 mm with one fastening element
- Flexible choice of material
- Customer-specific temperature requirements
- Adjustable damping properties
- Change in geometry
- Adaptation of the material Shore hardness



Pressing the mounting part into the receiving part – undercut for loss protection

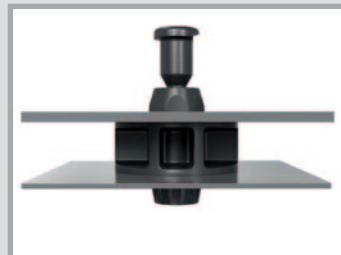

Pressing down the stud expands the bottom part

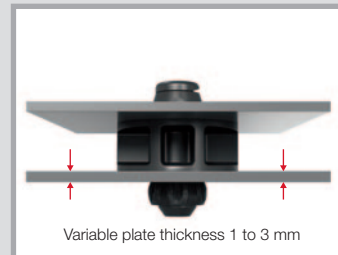

Plug-in process complete; plug-in connection with damping effect



<https://www.boellhoff.com/video/sitec-pin>



	Page
Vibration technology	5
<b>SITEC®</b> Variants – an overview	6
Materials	8
<b>SITEC®</b> Branches and applications	10
<h2>Damping</h2>	
<b>SITEC®</b> Rivet	12
<b>Standard design</b>	
■ with internal thread	14
■ without internal thread	17
■ Design and geometries	18
■ Choice of screws	19
■ Item codes and specifications	20
<b>Special versions</b>	
■ for high-temperature applications	22
■ for thread-forming screws	24
■ with pre-installed screw	25
<b>SITEC®</b> Pin	26
<b>SITEC®</b> Clip	30
<h2>Isolation</h2>	
<b>SITEC®</b> Spring	34
The Böllhoff competencies	38

## SITEC® Clip



A clip consisting of two parts is clipped into a sheet and through the soft external contour dampens its screw joint.

The SITEC® Clip is a comfortable and fast option to install a vibration damper for screw joints. After the SITEC® Clip has been installed on the component, the component can be transported without losing the fastener. The grip length is variable ranging between 1 and 3 mm. After that, the fastener is screwed to the respective mounting part with the internal thread. Moreover, the sleeve allows a radial tolerance compensation of  $\pm 1$  mm.

### Application example

The SITEC® Clip is perfectly suited to fasten medium-size applications. With its design, it can be used to fasten and decouple wiper motors, for example, with an additional damping effect.

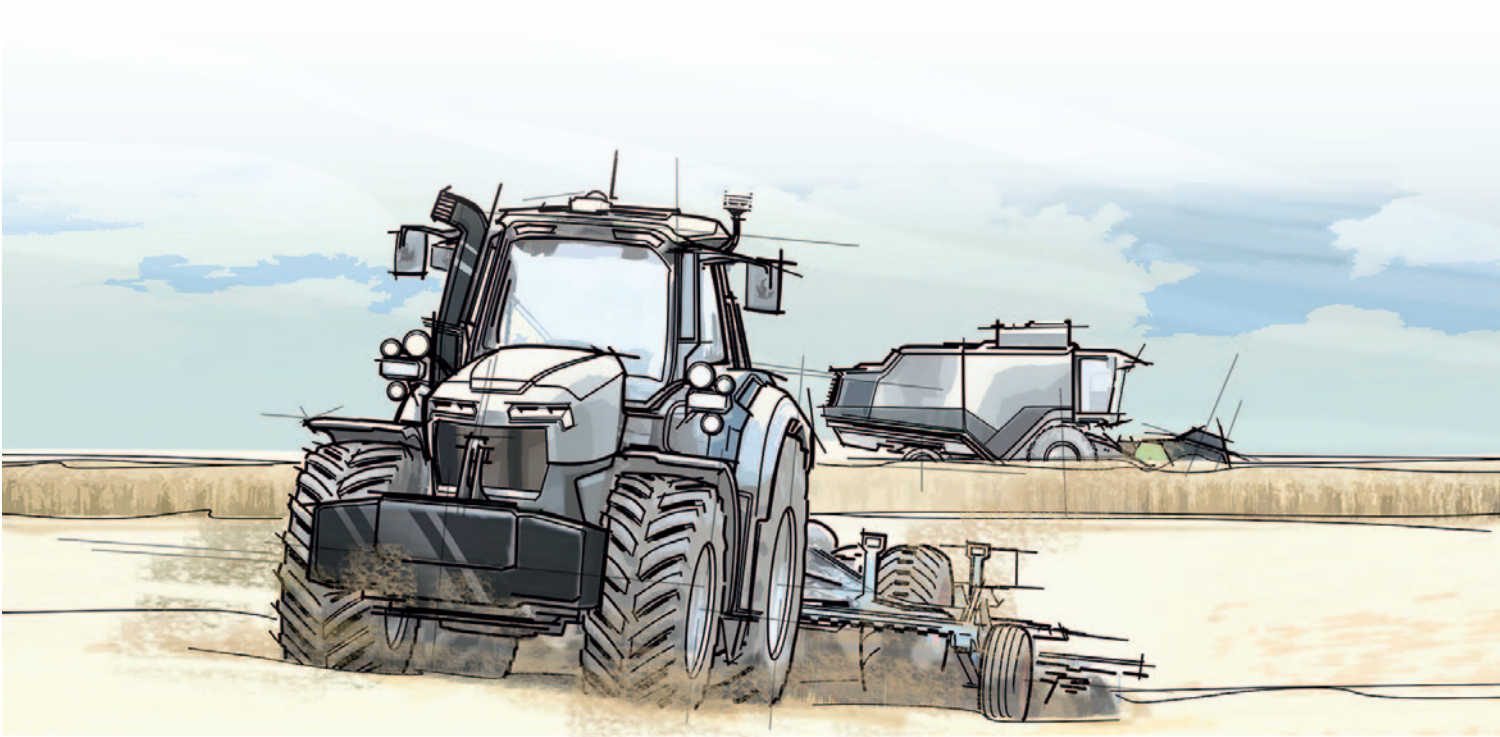

SITEC® Clip  
The decoupling clip  
system for screw joint  
— two-piece system



Introduction of the Clip  
bottom part through the  
bore hole in the mounting  
part

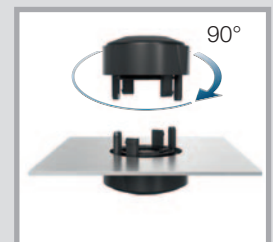

1) 90° turn of the Clip top  
part and insertion into the  
Clip bottom part  
2) Spring legs engage with  
the bottom part due to  
undercut



## Function

The SITEC® Clip is fast and easy to install on the plate geometry of your application. Two elements which are identical in design are – with an offset of 90° – clipped together in a round bore. The material thickness can vary between 1 and 3 mm. The fastener compensates those differences in geometry. Such as for the SITEC® Pin, the damping effect of the soft material and the adapted geometry easily physically convert vibration into heat. The peaks of the amplitude are therefore reduced and flattened.

The functional principle of the SITEC® Clip has been designed for all applications of this type. Below, you find the technical data for the application.

### Technical data (guideline values)

- Installation force of the fasteners of identical design: < 20 N
- Screw size: M 6
- Screw tightening torque: 10 Nm
- Weight to be fastened: 1 kg
- Continuous operating temperature: -40 °C to +100 °C
- Material: EPDM-X+PP

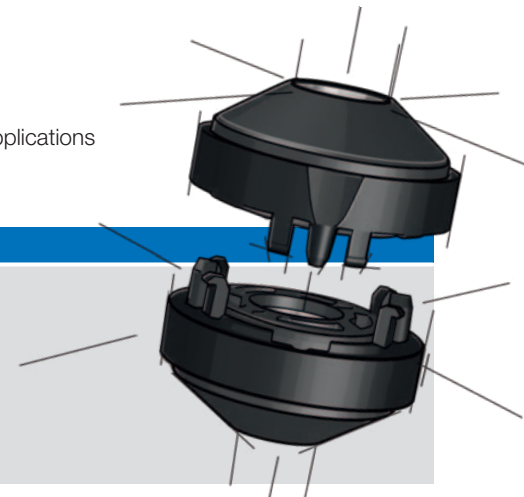

### Your advantages – an overview

- Pre- and final installation
- Fast, easy and with loss protection
- Without tool
- One fastening element for component thicknesses ranging between 1 and 3 mm
- Free choice of materials for your temperature range
- Adjustable damping properties
- Change in geometry
- Adaptation of the material Shore hardness
- Tightening torque according to property class 8.8
- Radial tolerance compensation within the fastener: ±1 mm



1) Pre-assembly with loss protection  
2) Alignment of the mounting part on the receiving part



Introduction of the screw through the metal sleeve of the SITEC® Clip and fastening with a weld nut on the rear of the receiving part

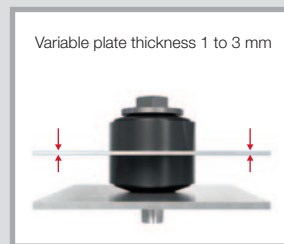

Screwing process complete; screw joint with damping effect



<https://www.boellhoff.com/video/sitec-clip>



	Page
Vibration technology	5
<b>SITEC®</b> Variants – an overview	6
Materials	8
<b>SITEC®</b> Branches and applications	10
<h2>Damping</h2>	
<b>SITEC®</b> Rivet	12
<b>Standard design</b>	
■ with internal thread	14
■ without internal thread	17
■ Design and geometries	18
■ Choice of screws	19
■ Item codes and specifications	20
<b>Special versions</b>	
■ for high-temperature applications	22
■ for thread-forming screws	24
■ with pre-installed screw	25
<b>SITEC®</b> Pin	26
<b>SITEC®</b> Clip	30
<h2>Isolation</h2>	
<b>SITEC®</b> Spring	34
The Böllhoff competencies	38

# SITEC® Spring



The purpose of the SITEC® Spring fastening element is to isolate vibration. Individually adjusted spring rates eliminate the vibration of large applications, for example in a vehicle. The assembly is delivered in two parts and is pre-assembled on your application without the use of tools so that it cannot be lost during transport. When it is then screwed together, the fastener can compensate radial tolerances of up to  $\pm 1$  mm.

### Apart from the variable spring rates, you can choose the type of fastening:

- Metric plastic or metal thread
- Self-tapping and self-locking plastic thread (K' in K')
- Bayonet quick release for manual installation

### Application example

The SITEC® Spring is perfectly suited to fasten larger applications. With its design, it can be used to fasten and decouple refrigeration compressors, for example, with an additional isolating effect.

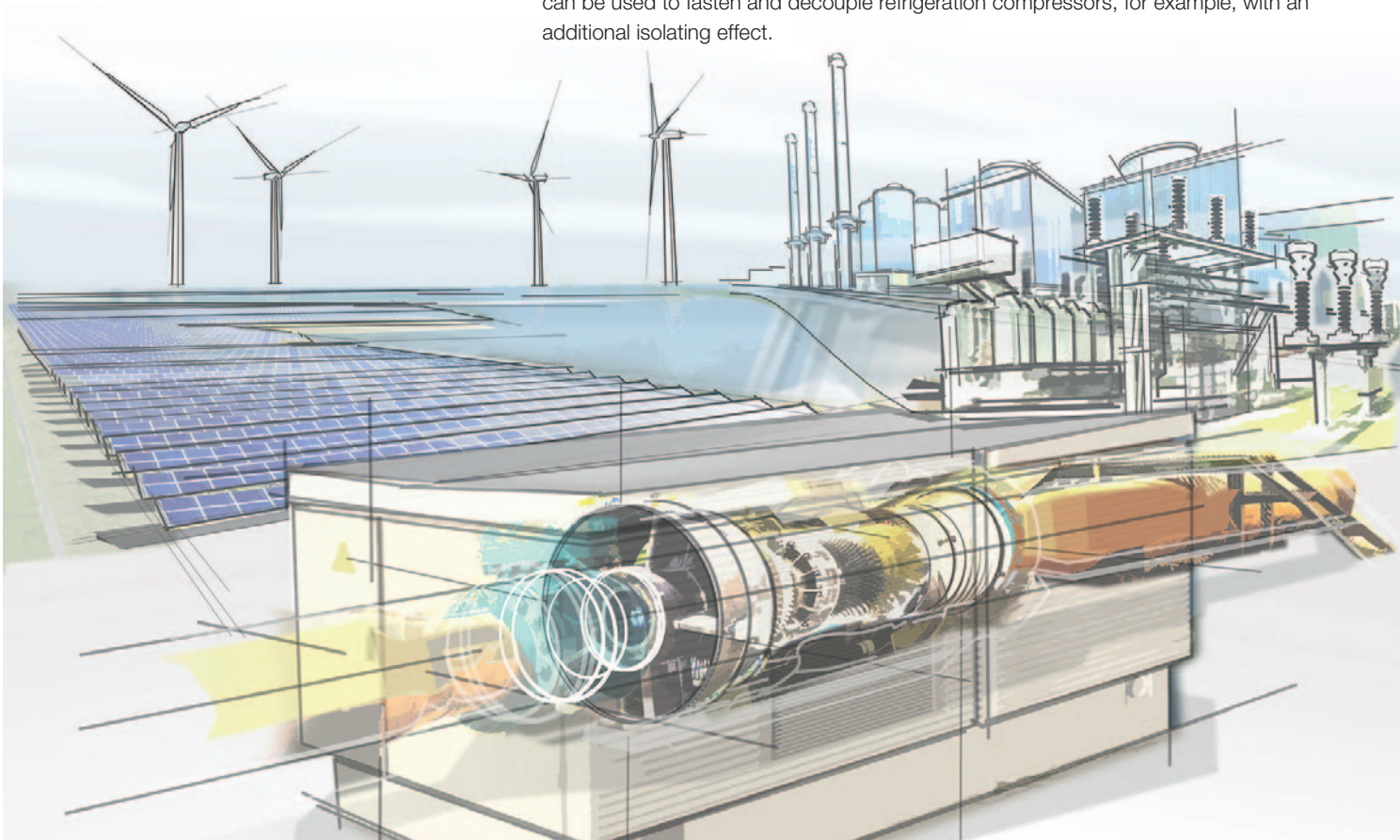

SITEC® Spring  
The decoupling spring system with screw connection  
– two-piece system



Pressing the damping element into the bore hole on the mounting part



Damping element pre-installed on the mounting part with loss protection

## Function

The SITEC® Spring can be easily installed on your component. The soft bottom part is inserted into the mounting hole. The screw can then be pushed into that assembly. No tool is therefore required to fasten the entire assembly with loss protection. The component part can then be screwed on to the body, for example, using the plastic thread.

The plug-plug-screw method is fast and assembly is easy. With the selected springs, the individually assembled fastener thus efficiently isolates the vibration of your application. The softer component functions as a soft end stop in the event of short-duration overload.

The functional principle of the SITEC® Spring has been designed for all applications of this type. Please find a short overview of the technical data below.

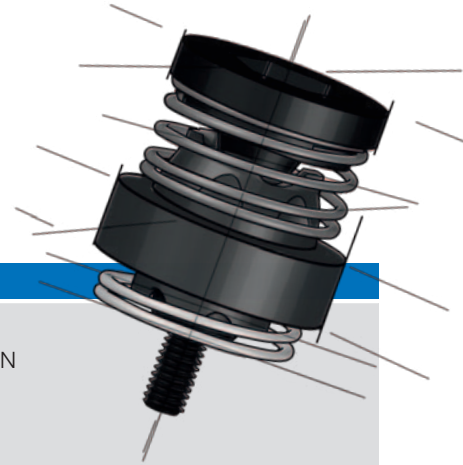

### Technical data (guideline values)

- Force for the installation of the 1<sup>st</sup> assembly into the application: < 20 N
- Force for the installation of the 2<sup>nd</sup> assembly into the 1st assembly: < 20 N
- Screw tightening torque: 3 Nm
- Weight to be fastened: 7 kg
- Continuous operating temperature: -40 °C to +140 °C
- Material: EPDM Peroxid

### Your advantages – an overview

- Pre- and final installation
- Fast, easy and with loss protection
- Without tool
- Free choice of materials for your temperature range
- Adjustable vibration-isolating properties
- Adjustment of the springs' spring rate
- Diverse fastening options
- Metric or self-tapping plastic or metal thread
- Radial tolerance compensation within the fastener: ±1 mm

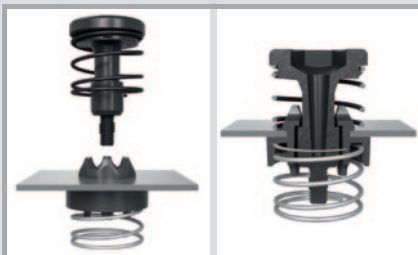

Insertion of the screw element into the pre-installed damping element – with loss protection



Screwing of the mounting part to the thread of the receiving part with the screw element

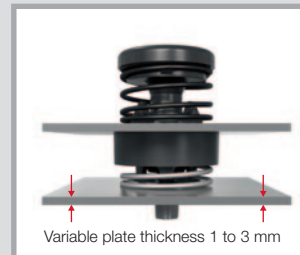

Screwing process complete; screw joint with vibration isolation



<https://www.boellhoff.com/video/sitec-spring>



## Your partner to succeed in joining – and what that means for you:

### Innovation and development partner

- Modern methods, organisational forms and processes
- Trend analyses
- Research cooperations
- Open innovation
- In-house research and development
- Application engineering and consulting
- Customer-specific development parts
- Manufacture of samples and prototypes
- Value analyses

### Procurement and assembly partner

- Engineering competence thanks to in-house production
- Twelve modern production facilities worldwide
- Production methods
  - injection moulding
  - turning
  - cold working
  - wire winding
  - mechanical and plant engineering
- Acceleration of your assembly processes
- Wide range of manual and automated assembly solutions



We are looking forward to our next  
**joint success story.**

## Logistics and quality partner

- Supply chain solutions
- Quality management according to IATF 16949
- Quality management according to EN 9100
- Distinctive quality and environmental awareness
  - accreditation of the in-house laboratory according to DIN EN ISO/IEC 17025
  - certification according to DIN EN ISO 14001
- Regular audits through customers

## Distributor and service partner

- Efficient consulting, assistance and service
- Expert specialists on site
- Proximity to customers thanks to global presence
- After sales service
- Expert seminars, training sessions and workshops
- Webinars
- Customer in-house fairs

# BÖLLHOFF



## **Böllhoff Group**

Innovative partner for joining technology with assembly and logistics solutions.

Find your local partner at [www.boellhoff.com](http://www.boellhoff.com) or contact us at [fat@boellhoff.com](mailto:fat@boellhoff.com).

**Passion for successful joining.**